

Poly-Tite® Fittings

Advantages

A compact brass compression fitting designed to speed any installation. Body, nut and sleeve are furnished pre-assembled, ready for installation. An exclusive acetal copolymer sleeve holds plastic tubing where it belongs, even when the system pressure exceeds the tubing burst point. Poly-Tite sleeves have superior resilience to resist creeping and stress caused from compression. The black acetal copolymer sleeve also resists ultra-violet ray attack and has excellent dimensional stability. Poly-Tite nuts will rotate around the sleeve as it tightens to prevent twisting and weakening of the plastic tubing. Poly-Tite fittings can be assembled and disassembled repeatedly.

Materials

Bodies and Nuts: CA 377, CA 360, CA 345
 Plastic Sleeves: Acetal Copolymer.

Applications

Use with Parker Parflex® or other high-quality thermoplastic tubing for pneumatic instrumentation circuits, lubricant and coolant lines, and applications with other gases and liquids. For use with soft metal tubing and nylon thermoplastic tubing, use brass sleeve and nut assembly 61PB.

Working Pressure and Temperature Ranges

Up to 150 PSI from 0° to +150°F with thermoplastic tubing. Up to 300 PSI from 0° to +175°F with soft metal tubing.

Assembly Instructions

Polyethylene, polypropylene and vinyl tubing:

1. Cut tubing squarely—maximum of 15° angle allowable.
2. Check that port or mating part is clean and free of debris.
3. Insert tube end until it bottoms in the Poly-Tite fitting and tighten knurl/hex nut finger-tight — plus one wrench turn.

Copper, aluminum and nylon tubing:

Brass sleeves are recommended. Insert tube until it bottoms in the Poly-Tite fitting and tighten one wrench turn past finger-tight.

Maximum allowable metal tube wall thickness for use with

Poly-Tite fittings:

1/8", 3/16" O.D. — no limitation, 1/4" O.D. — .035
 5/16", 3/8", 1/2" O.D. — .049

Order

By part number and name.

Nomenclature

Part numbers are constructed from symbols that identify the style and size of the fitting. The first series of numbers and letters identifies the style and type fitting. The second series of numbers describes the size.

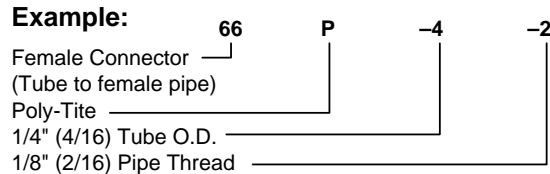

Sizes

Tube sizes are determined by the number of sixteenths of an inch in the tube O.D.

Special Fittings

Fitting configurations and/or sizes other than those shown in the catalog can be furnished. It is suggested that a print or sketch be submitted with the inquiry.

Pricing

Only items priced in current supplementary price list PL3501 are carried in stock. Price and delivery for nonstock items furnished on request for specified quantity.

Tube Support O.D.

Tube Size Inches	* D1 Tube Support O.D.
1/4	.168
5/16	.185
3/8	.248
1/2	.373

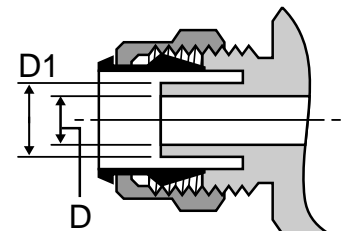

* Note: No tube support for sizes 1/8" and 3/16"

Poly-Tite® Fittings

Plastic cap 59P

PART NO.	TUBE SIZE	A	L
59P-4	1/4	.247	.50
59P-5	5/16	.307	.53
59P-6	3/8	.372	.56
59P-8	1/2	.497	.63

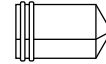
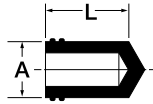

Acetal plastic sleeve 60P

PART NO.	TUBE SIZE	A	D	L
60P-4	1/4	.336	.258	.35
60P-5	5/16	.400	.320	.34
60P-6	3/8	.460	.382	.37
60P-8	1/2	.627	.508	.42

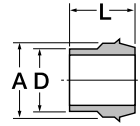

Sleeve 60PB

PART NO.	L	O.D.	I.D.
60PB-2	.187	.256	.130
60PB-3	.187	.322	.192
60PB-4	.187	.336	.255
60PB-5	.187	.400	.318
60PB-6	.218	.460	.382
60PB-8	.250	.620	.507

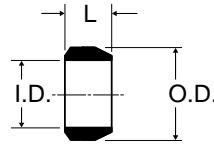

Nut and plastic sleeve assembly 61P

PART NO.	TUBE SIZE	STRAIGHT THREAD	C HEX	D	L
61P-2*	1/8	5/16-24	3/8	.130	.34
61P-3*	3/16	3/8-24	7/16	.194	.37
61P-4	1/4	3/8-24	7/16	.258	.38
61P-5	5/16	7/16-24	1/2	.320	.34
61P-6	3/8	1/2-24	9/16	.382	.38
61P-8	1/2	11/16-20	3/4	.508	.44

* Brass Sleeve

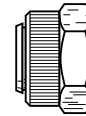
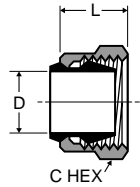

Nut and brass sleeve assembly 61PB

PART NO.	TUBE SIZE	STRAIGHT THREAD	C HEX	D	L
61PB-4	1/4	3/8-24	7/16	.258	.38
61PB-5	5/16	7/16-24	1/2	.320	.34
61PB-6	3/8	1/2-24	9/16	.382	.38
61PB-8	1/2	11/16-20	3/4	.508	.44

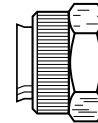
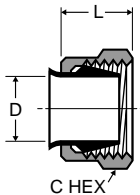

Nut 61PN

PART NO.	TUBE SIZE	STRAIGHT THREAD	C HEX	L
61PN-2	1/8	5/16-24	3/8	.34
61PN-3	3/16	3/8-24	7/16	.37
61PN-4	1/4	3/8-24	7/16	.38
61PN-5	5/16	7/16-24	1/2	.34
61PN-6	3/8	1/2-24	9/16	.38
61PN-8	1/2	11/16-20	3/4	.44

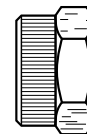
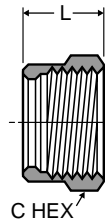

Union 62P

PART NO.	TUBE SIZE	STRAIGHT THREAD	C HEX	L	M	FLOW DIA. D
62P-2*	1/8	5/16-24	5/16	1.08	.64	.094
62P-3*	3/16	3/8-24	3/8	1.17	.72	.125
62P-4	1/4	3/8-24	3/8	1.17	.96	.125
62P-5	5/16	7/16-24	7/16	1.17	.96	.144
62P-6	3/8	1/2-24	1/2	1.23	.99	.204
62P-8	1/2	11/16-20	11/16	1.39	1.24	.323

* Brass Sleeve, No Tube Support

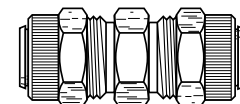
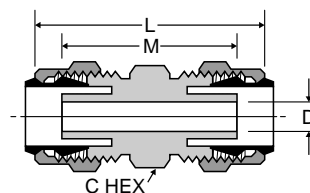

Union Reducer 62P

PART NO.	1 TUBE SIZE	2 TUBE SIZE	1 STRAIGHT THREAD	2 STRAIGHT THREAD	C HEX	L	M	FLOW DIA. D
62P-6-4	1/4	3/8	3/8-24	1/2-24	1/2	1.21	.99	.125

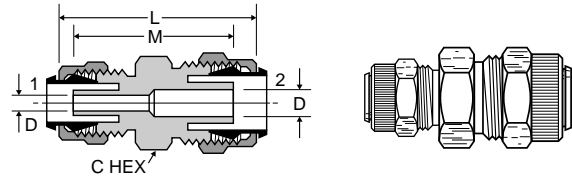

Bulkhead union 62PBH

PART NO.	TUBE SIZE	STRAIGHT THREAD	C HEX	P MAX.	L	M	FLOW DIA. D
62PBH-4	1/4	3/8-24	9/16	.38	1.74	1.52	.125
62PBH-5	5/16	7/16-24	5/8	.38	1.70	1.52	.144
62PBH-6	3/8	1/2-24	11/16	.47	1.89	1.65	.204
62PBH-8	1/2	11/16-20	7/8	.63	2.20	2.05	.323

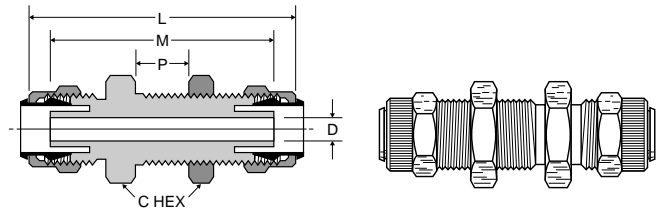

Union 62PCA

(Tube to Compress-Align)

PART NO.	TUBE SIZE	1 STRAIGHT THREAD	2 STRAIGHT THREAD	C HEX	L	M	FLOW DIA. D
62PCA-4	1/4	3/8-24	7/16-24	7/16	1.24	.89	.125
62PCA-5	5/16	7/16-24	1/2-24	1/2	1.32	.98	.144
62PCA-6	3/8	1/2-24	9/16-24	9/16	1.32	.98	.204

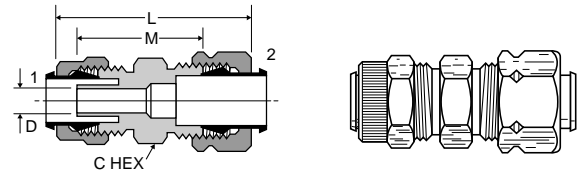

Bulkhead union 62PCABH

(Tube to Compress-Align)

PART NO.	TUBE SIZE	1 STRAIGHT THREAD	2 STRAIGHT THREAD	C HEX	P MAX.	L	M	FLOW DIA. D
62PCABH-4	1/4	3/8-24	7/16-24	9/16	.38	1.80	1.45	.125
62PCABH-6	3/8	1/2-24	9/16-24	11/16	.47	1.98	1.64	.204

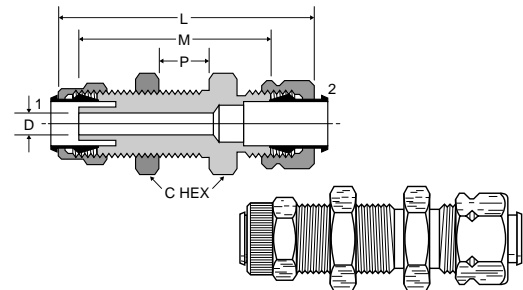

Bulkhead union 62PTBH

(Straight Through)

PART NO.	TUBE SIZE	STRAIGHT THREAD	C HEX	P MAX.	L	M	FLOW DIA. D
62PTBH-4	1/4	3/8-24	9/16	.31	1.19	.93	.260
62PTBH-5	5/16	7/16-24	5/8	.31	1.19	.93	.323
62PTBH-6	3/8	1/2-24	11/16	.34	1.26	.99	.387

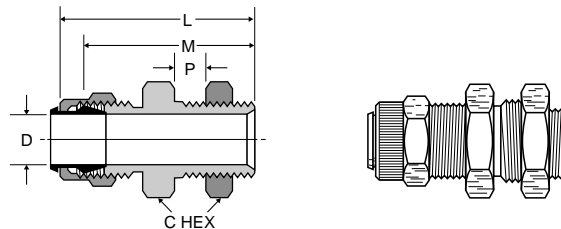

Brass insert 63PT

PART NO.	TUBE SIZE	L	O.D.
63PT-2-16	1/8	.46	.080
63PT-2-32	1/8	.31	.061
63PT-3-25	3/16	.45	.135
63PT-3-40	3/16	.52	.095

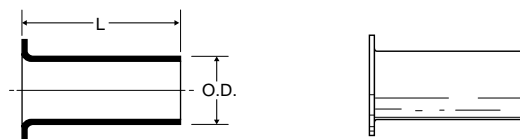

Poly-Tite® Fittings

Female connector 66P

PART NO.	TUBE SIZE	PIPE THREAD	STRAIGHT THREAD	C HEX	L	M	FLOW DIA. D
66P-2-2*	1/8	1/8	5/16-24	9/16	.97	.75	.094
66P-3-2*	3/16	1/8	3/8-24	9/16	1.00	.78	.125
66P-3-4*	3/16	1/4	3/8-24	11/16	1.18	.96	.125
66P-4-2	1/4	1/8	3/8-24	1/2	.97	.86	.125
66P-4-4	1/4	1/4	3/8-24	5/8	1.18	1.07	.125
66P-5-2	5/16	1/8	7/16-24	1/2	.97	.86	.144
66P-6-4	3/8	1/4	1/2-24	5/8	1.18	1.07	.204
66P-8-6	1/2	3/8	11/16-20	13/16	1.31	1.20	.323

*Brass Sleeve, No Tube Support

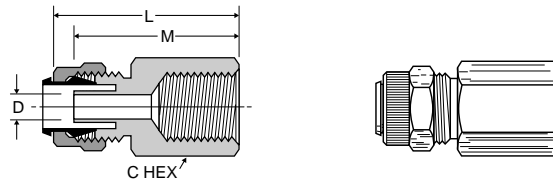

Male connector 68P

PART NO.	TUBE SIZE	PIPE THREAD	STRAIGHT THREAD	C HEX	L	M	FLOW DIA. D
68P-2-1*	1/8	1/16	5/16-24	11/32	1.00	.78	.094
68P-2-10X32*	1/8	10-32	5/16-24	3/8	.86	.64	.094
68P-2-2*	1/8	1/8	5/16-24	7/16	.99	.77	.094
68P-3-2*	3/16	1/8	3/8-24	7/16	1.06	.84	.125
68P-3-4*	3/16	1/4	3/8-24	9/16	1.25	1.03	.125
68P-4-1	1/4	1/16	3/8-24	3/8	1.06	.95	.125
68P-4-10X32	1/4	10-32	3/8-24	3/8	.86	.75	.094
68P-4-2	1/4	1/8	3/8-24	7/16	1.06	.95	.125
68P-4-4	1/4	1/4	3/8-24	9/16	1.25	1.14	.125
68P-4-6	1/4	3/8	3/8-24	11/16	1.28	1.17	.125
68P-5-2	5/16	1/8	7/16-24	7/16	1.05	.95	.144
68P-5-4	5/16	1/4	7/16-24	9/16	1.24	1.14	.144
68P-6-2	3/8	1/8	1/2-24	1/2	1.10	.98	.204
68P-6-4	3/8	1/4	1/2-24	9/16	1.29	1.17	.204
68P-6-6	3/8	3/8	1/2-24	11/16	1.29	1.17	.204
68P-8-6	1/2	3/8	11/16-20	11/16	1.37	1.29	.323

*Brass Sleeve, No Tube Support

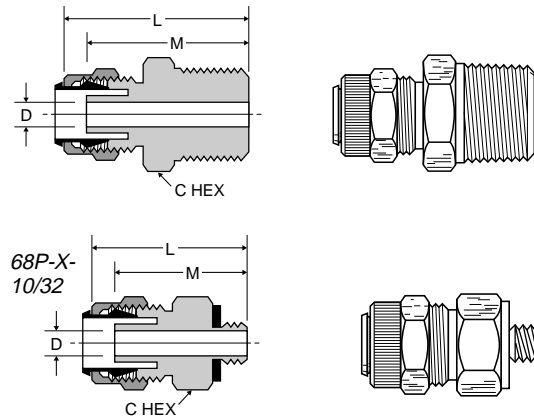

Pipe coupler body 391P

(Chrome Plated)

PART NO.	D-INSERT DIA.	PIPE THREAD	C HEX	H	L
391P-4-2	1/4	1/8	1/2	.91	1.29
391P-4-4	1/4	1/4	9/16	.73	1.29
391P-6-4	3/8	1/4	5/8	.85	1.41

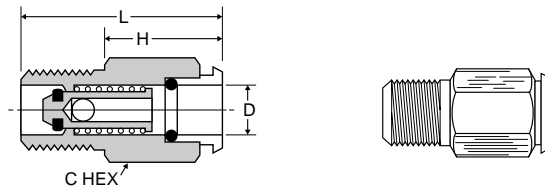

Bulkhead coupler body 392P

(Chrome Plated)

PART NO.	TUBE SIZE	D-INSERT DIA.	STRAIGHT THREAD	C HEX	P MAX.	H	L
392P-4-4	1/4	1/4	1/2-24	5/8	.84	.39	2.13
392P-6-6	3/8	3/8	11/16-24	13/16	.93	.37	2.01

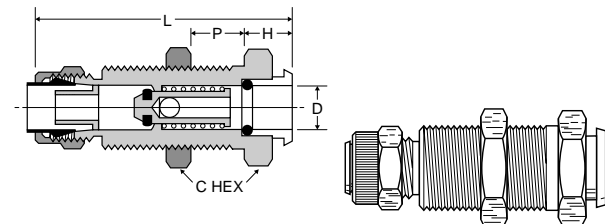

Through type insert 393P

(Chrome Plated)

PART NO.	TUBE SIZE	D-INSERT DIA.	STRAIGHT THREAD	C SQUARE	H	FLOW DIA. F
393P-4-4	1/4	1/4	3/8-24	7/16	.96	.125
393P-6-6	3/8	3/8	1/2-24	1/2	1.26	.203

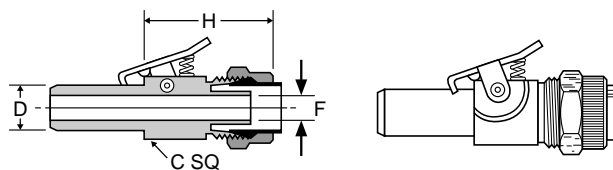

Shutoff type insert 393PD

(Chrome Plated)

PART NO.	TUBE SIZE	D-INSERT DIA.	STRAIGHT THREAD	C SQUARE	H	FLOW DIA.F
393PD-4-4	1/4	1/4	3/8-24	7/16	1.61	.125
393PD-6-6	3/8	3/8	1/2-24	1/2	1.45	.204

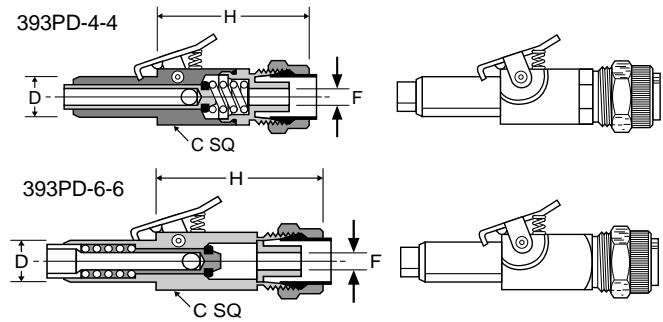

Single end shutoff bulkhead quick coupler 394P

(Chrome Plated)

PART NO.	TUBE SIZE	STRAIGHT THREAD	C HEX	P MAX.	H	L	M	FLOW DIA.F
394P-4-4	1/4	1/2-24	5/8	.84	.39	3.13	2.13	.125
394P-6-6	3/8	11/16-24	13/16	.93	.37	3.30	2.01	.203

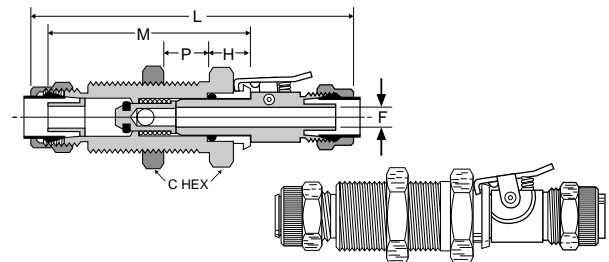

Double end shutoff bulkhead quick coupler 394PD

(Chrome Plated)

PART NO.	TUBE SIZE	STRAIGHT THREAD	C HEX	P MAX.	H	L	M	FLOW DIA.F
394PD-4-4	1/4	1/2-24	5/8	.84	.39	3.77	2.13	.125
394PD-6-6	3/8	11/16-24	13/16	.93	.37	3.40	2.01	.204

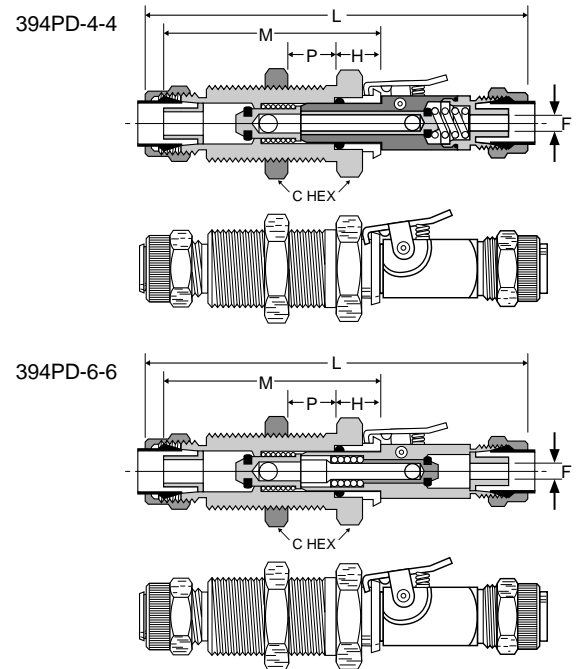

Single end shutoff pipe connector quick coupler 398P

(Chrome Plated)

PART NO.	TUBE SIZE	PIPE THREAD	STRAIGHT THREAD	C HEX	L	M	FLOW DIA.F
398P-4-2	1/4	1/8	3/8-24	1/2	2.28	1.29	.125
398P-4-4	1/4	1/4	3/8-24	9/16	2.28	1.29	.125
398P-6-4	3/8	1/4	1/2-24	5/8	2.69	1.41	.203

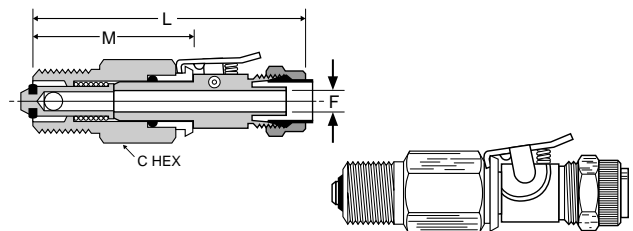

Poly-Tite® Fittings

Double end shutoff pipe connector quick coupler 398PD

(Chrome Plated)

PART NO.	TUBE SIZE	PIPE THREAD	STRAIGHT THREAD	C HEX	L	M	FLOW DIA.F
398PD-4-2	1/4	1/8	3/8-24	1/2	2.93	1.29	.125
398PD-4-4	1/4	1/4	3/8-24	9/16	2.93	1.29	.125
398PD-6-4	3/8	1/4	1/2-24	5/8	2.80	1.41	.204

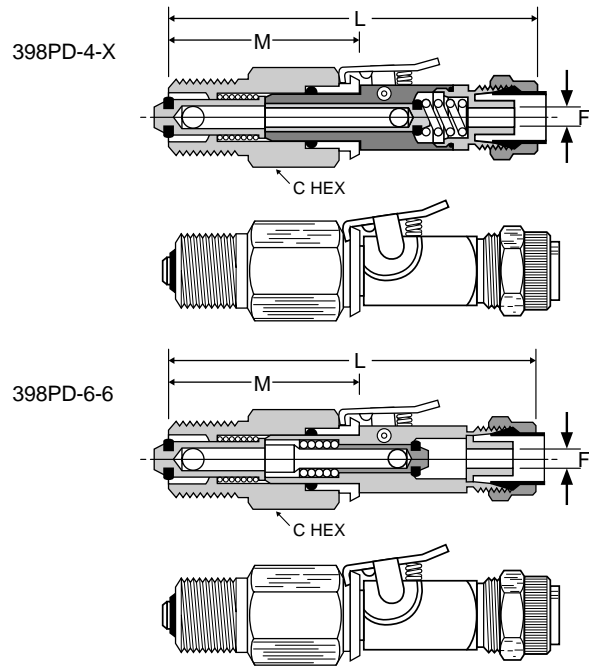

Union tee 164P

PART NO.	TUBE SIZE	STRAIGHT THREAD	L	M	FLOW DIA.D
164P-2*	1/8	5/16-24	.83	.61	.094
264P-3*	3/16	3/8-24	.83	.61	.125
164P-4	1/4	3/8-24	.84	.73	.125
164P-5	5/16	7/16-24	.83	.73	.144
164P-6	3/8	1/2-24	.98	.86	.203
164P-8	1/2	11/16-20	1.12	1.04	.323

*Brass Sleeve, No Tube Support

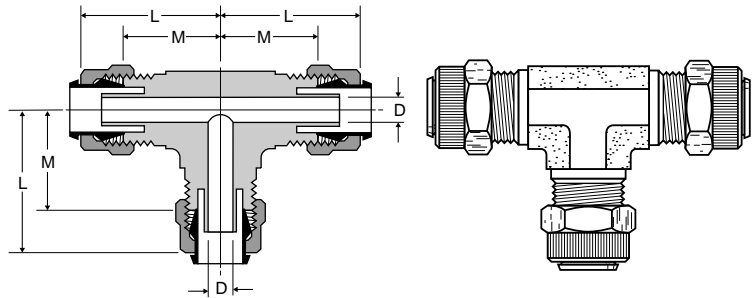

Union tee 164P combination size

PART NO.	1 TUBE SIZE	2 TUBE SIZE	3 TUBE SIZE	L	L1	M	M1	FLOW DIA.D
164P-6-4	3/8	3/8	1/4	.98	.90	.86	.79	.125

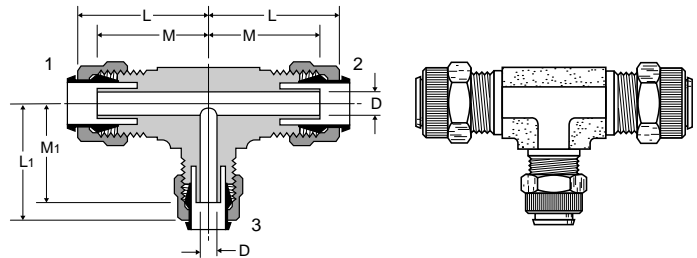

Male elbow 169P/269P

PART NO.	TUBE SIZE	PIPE THREAD	STRAIGHT THREAD	L	M	N	FLOW DIA.D
269P-2-2*	1/8	1/8	5/16-24	.83	.61	.67	.094
169P-3-2*	3/16	1/8	3/8-24	.83	.61	.69	.125
169P-3-4*	3/16	1/4	3/8-24	.85	.63	.94	.125
169P-4-2	1/4	1/8	3/8-24	.84	.73	.75	.125
169P-4-4	1/4	1/4	3/8-24	.90	.79	.92	.125
169P-4-6	1/4	3/8	3/8-24	.93	.82	1.08	.125
169P-5-2	5/16	1/8	7/16-24	.87	.77	.72	.144
169P-6-2	3/8	1/8	1/2-24	.91	.79	.73	.203
169P-6-4	3/8	1/4	1/2-24	.98	.86	1.05	.203
169P-6-6	3/8	3/8	1/2-24	.98	.86	1.08	.203
169P-8-6	1/2	3/8	11/16-20	1.12	1.04	1.13	.323

*Brass Sleeve, No Tube Support

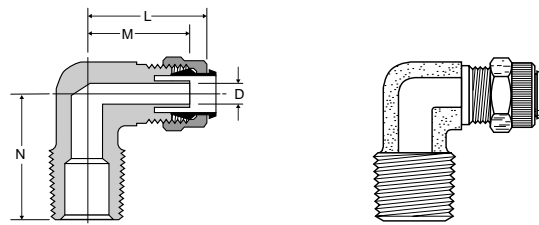

Long male elbow 169LP

PART NO.	TUBE SIZE	PIPE THREAD	STRAIGHT THREAD	L	M	N	FLOW DIA.D
169LP-4-4	1/4	1/4	3/8-24	.90	.79	1.38	.125

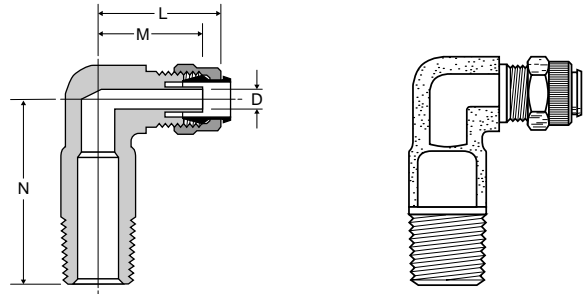

Female elbow 170P

PART NO.	TUBE SIZE	PIPE THREAD	STRAIGHT THREAD	L	M	N	FLOW DIA.D
170P-2-2*	1/8	1/8	5/16-24	.91	.69	.56	.094
170P-3-2*	3/16	1/8	3/8-24	.91	.69	.56	.125
170P-4-2	1/4	1/8	3/8-24	.90	.79	.56	.125
170P-4-4	1/4	1/4	3/8-24	1.00	.89	.69	.125
170P-6-4	3/8	1/4	1/2-24	1.01	.89	.69	.204
170P-8-6	1/2	3/8	11/16-20	1.19	1.11	1.13	.323

*Brass Sleeve, No Tube Support

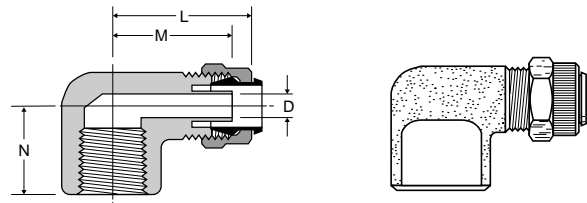

Male run tee 171P

PART NO.	TUBE SIZE	PIPE THREAD	STRAIGHT THREAD	L	M	N	FLOW DIA.D
171P-2-2*	1/8	1/8	5/16-24	.83	.61	.71	.094
171P-3-2*	3/16	1/8	3/8-24	.83	.61	.71	.125
171P-4-2	1/4	1/8	3/8-24	.84	.73	.72	.125
171P-4-4	1/4	1/4	3/8-24	.92	.81	.92	.125
171P-5-2	5/16	1/8	7/16-24	.83	.73	.72	.144
171P-6-4	3/8	1/4	1/2-24	.98	.86	1.03	.203
171P-8-6	1/2	3/8	11/16-20	1.12	1.04	1.13	.323

*Brass Sleeve, No Tube Support

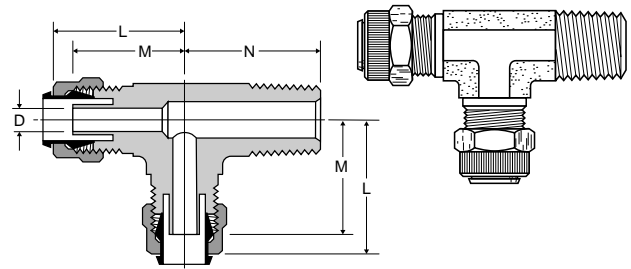

Male branch tee 172P

PART NO.	TUBE SIZE	PIPE THREAD	STRAIGHT THREAD	L	M	N	FLOW DIA.D
172P-2-2*	1/8	1/8	5/16-24	.83	.61	.71	.094
172P-3-2*	3/16	1/8	3/8-24	.83	.61	.71	.125
172P-4-2	1/4	1/8	3/8-24	.84	.73	.72	.125
172P-4-4	1/4	1/4	3/8-24	.92	.81	.92	.125
172P-5-2	5/16	1/8	7/16-24	.83	.73	.72	.144
172P-6-4	3/8	1/4	1/2-24	.98	.86	1.03	.203
172P-8-6	1/2	3/8	11/16-20	1.12	1.04	1.13	.323

*Brass Sleeve, No Tube Support

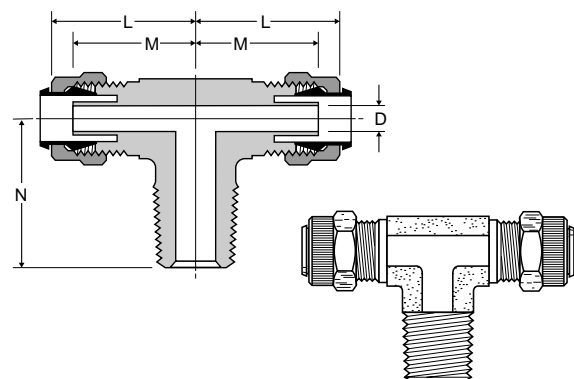

Poly-Tite® Fittings

Female branch tee 177P

PART NO.	TUBE SIZE	PIPE THREAD	STRAIGHT THREAD	L	M	N	FLOW DIA.D
177P-4-2	1/4	1/8	3/8-24	.92	.81	.88	.125
177P-4-4	1/4	1/4	3/8-24	.90	.79	1.03	.125
177P-4-6	1/4	3/8	3/8-24	1.03	.92	1.13	.125

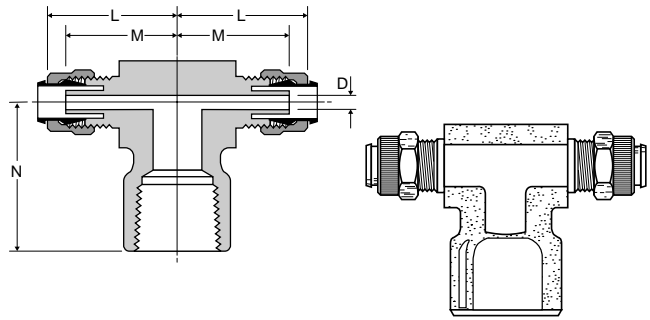

Needle valve NV311P

PART NO.	TUBE SIZE	PIPE THREAD	H	L OPEN	L CLOSED	M	N
NV311P-4-2	1/4	1/8	1.06	1.36	1.16	.64	.63
NV311P-4-4	1/4	1/4	1.06	1.38	1.18	.64	.72
NV311P-6-4	3/8	1/4	1.06	1.38	1.18	.64	.72

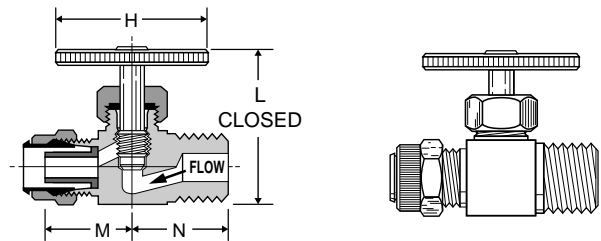

Angle needle valve NV312P

PART NO.	TUBE SIZE	PIPE THREAD	H	L OPEN	L CLOSED	M	N
NV312P-4-2	1/4	1/8	1.06	1.70	1.50	.63	.68
NV312P-4-4	1/4	1/4	1.06	2.07	1.82	.71	.86
NV312P-6-4	3/8	1/4	1.06	2.00	1.75	.79	.86

