

Female/Female Straight Thread Brass Ball Valve Series 506

Advantages

Parker's forged body ball valve provides extended service life and resists failure caused by severe temperature applications. Optimum flow design assures maximum system efficiency. Highly inert PTFE seats and seals provide resistance to chemical corrosion. Parker also provides a blow-out proof stem, chrome plated brass ball and a specially designed handle enabling increased turning leverage for ease of opening and closing. Parker's ball valve can be readily identified assuring high quality engineering and reliability. This ball valve is available in 1/4" through 2" female straight thread sizes. Parker's ball valve bodies are machined from high quality CA 377 forgings.

Applications

Parker's industrial ball valve product line is intended for general purpose use. Please be aware that ball valves are intended for use in the fully open or closed positions. Depending on application conditions, throttling of the valve may result in premature seal failure and/or inability to turn the valve handle.

For use on construction equipment, chemical processing, plastic and rubber manufacturing, pumps and specialized industrial machinery requiring total shut-off capability.

Working Pressure and Temperature

Saturated steam service up to 150 PSI and 400° F
Vacuum, 29 Inches of Mercury

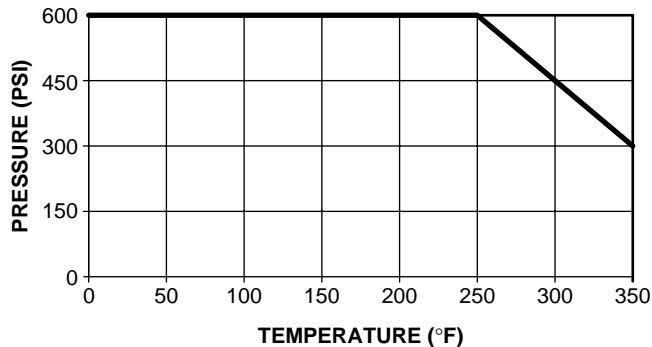

Operating Instructions

Quarter turn is "ON" or "OFF".
(Provides positive stop action for full shutoff.)

NOTE: PERIODICALLY CHECK THE ADJUSTABLE PACKING NUT AND TIGHTEN AS REQUIRED.

Style	Type	Material	Size	Options
V	506	P	-4	-00
Style	V-Valve VP-Valve, Padlocking Handle			
Type	506 Female/Female			
Material	P- Brass			
Size	4-1/4" 6-3/8" 8-1/2" 12-3/4" 16-1"			
Options	01-Stainless Steel Ball & Stem 02-Stainless Steel Handle & Nut 03-Stainless Steel Ball, Stem, Handle & Nut 04-Tee Handle 08-Unmarked Yellow Vinyl Handle Cover 21-Oval Handle			

Flow Data

VALVE SIZE	CV
1/4	4.0
3/8	5.8
1/2	12.0
3/4	35.0
1	54.0

Style	Type	Material	Size
V	506	P	-20
Style	V-Valve		
Type	506 Female/Female		
Material	P- Brass		
Size	20 - 1 1/4" 24 - 1 1/2" 32 - 2"		

Female/Female Straight Thread Brass Ball Valve Series 506

Female/Female, Straight Thread O-Ring Port XV506P

PART NO.	STRT. THREAD	B HEX	C HEX	H	L	M	N	D FLOW Ø
XV506P-4	7/16-20	15/16	15/16	3.96	5.01	2.20	2.47	.375
XV506P-6	9/16-18	15/16	15/16	3.96	5.07	2.26	2.47	.375
XV506P-8	3/4-16	1-1/16	1-1/16	3.96	5.18	2.42	2.60	.500
XV506P-12	1-1/16-12	1-1/4	1-5/16	3.96	5.87	3.46	2.81	.685
XV506P-16	1-5/16-12	1-1/2	1-9/16	3.96	5.96	3.68	3.08	.875

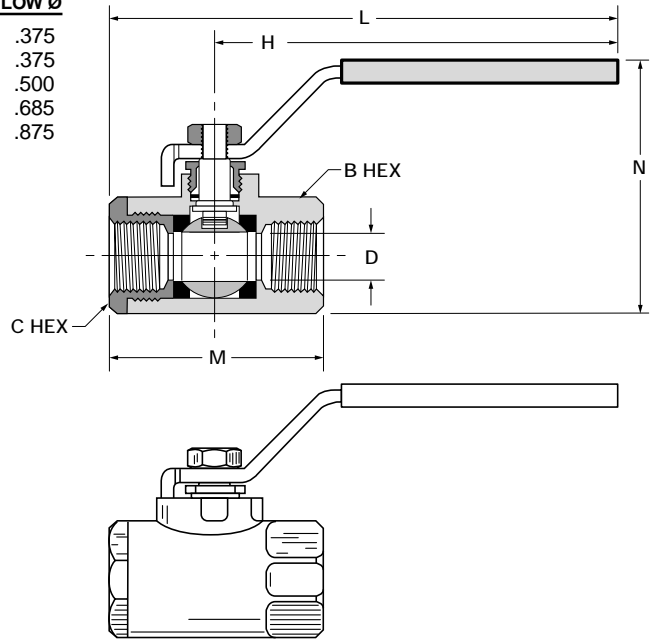

Female/Female, Straight Thread O-Ring Port XV506P-20, XV506P-24, XV506P-32

PART NO.	STRT. THREAD	B OCT	C OCT	H	L	M	N	D FLOW Ø
XV506P-20	1 5/8-12	1.93	1.93	6.22	8.05	3.66	3.01	1.18
XV506P-24	1 7/8-12	2.13	2.13	6.22	8.23	4.02	3.25	1.50
XV506P-32	2 1/2-12	2.85	2.85	6.22	8.60	4.76	3.52	1.89

